

MACCHINE SOTTOVUOTO
VACUUM MACHINE
ENVASADORAS DE CAMPANA
MACHINES À VIDE

ST
PROFESSIONAL

Waage
by Vetrella

500



CARATTERISTICHE
Sistema temporizzato
Pannello comandi antigraffio e anti liquidi
2 modi di lavoro dedicati alla preparazione in sottovuoto
9 programmi memorizzabili
riscaldamento pompa
deumidificazione pompa H2O
stop ciclo di lavoro
Saldatura anticipata

CHARACTERISTICS
Timed system
Scratch-proof and liquid-proof control panel
2 working modes dedicated to vacuum preparation
9 storable programs
pump heating
H2O pump dehumidification
working cycle stop
early sealing

CARACTERÍSTICAS
Sistema temporizado
Panel de control antirayaduras y antilíquidos
2 modos de trabajo dedicados a la preparación del vacío
9 programas almacenables
Precalentamiento bomba de vacío
dehumidificación bomba de vacío H2O
Posibilidad de parar el ciclo de vacío
Sellado adelantado

CARACTÉRISTIQUES
Système temporisé
Panneau de commande antirayures et anti-liquide
2 modes de travail dédiés à la préparation sous vide
9 programmes mémorisables
Chauffage pompe
pompe de déshumidification H2O
arrêt du cycle de travail
soudage anticipée

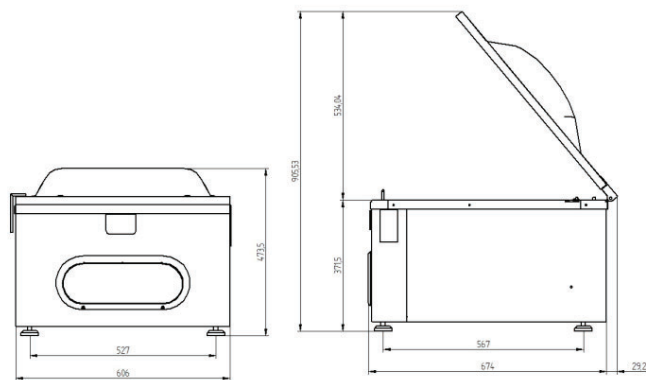
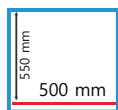

Modello	Dimensione macchina	Dimensione Vasca	Pompa vuoto	Barra saldante	Gas inerte (optional)	Alimentazione	Peso	Max buste
Model	overall dimension	chamber dimension	vacuum pump	sealing bar	Inert gas	voltage	weight	max buste
Modelo	dimensiones	dimensiones cuba	bomba de vacío	barra soldante	inyeccion gas	alimentación	peso	bolsas máx.
Modèle	dimènsions	dimènsions de la cuve	pompe de vide	barre de soudure	gaz inerte	alimentation	poids	max d'enveloppes
ST 500	612x667x370 mm	512x550x200 mm	25 m ³ /h	510 mm	2 ugelli	220 V-50-60 Hz 1500 w	75 kg	500x550 mm

Optional su richiesta - Optional on request - Opcionales sobre pedido - En option sur demande



Motore busch (uguale potenza)
Inert gas
Bomba de vacío busch



Gas inerte
Inert gas
Gas alimentar
Gaz inerte



Taglio sfrido
Cut of seal
Corte de la bolsa
Coupe de ferraille



Piano inclinato
inclined plane
Plano integrada
Plan incliné